

THANKS FOR PURCHASING OUR PRODUCT

**PAC40M**

**DC INVERTER  
AIR PLASMA  
CUTTING MACHINE**

# **OPERATION INSTRUCTIONS**

(BE SUITABLE FOR 1x230V)



# SAFETY PRECAUTIONS

**Follow these precautions carefully. Improper use of any welder can result in injury or death.**

1. ONLY CONNECT WELDER TO A POWER SOURCE FOR WHICH IT WAS DESIGNED. The specification plate on the welder lists this information. When welding outdoors only use an extension cord intended for such use.
2. ONLY OPERATE WELDER IN DRY LOCATIONS and on cement or masonry floor. Keep area clean and un-cluttered.
3. KEEP ALL COMBUSTIBLES AWAY FROM WORK SITE.
4. DO NOT WEAR CLOTHING THAT HAS BEEN CONTAMINATED with grease or oil.
5. KEEP CABLES DRY AND FREE FROM OIL AND GREASE and never coil around shoulders.
6. SECURE WORK WITH CLAMPS or other means; don't overreach when working.
7. NEVER STRIKE AN ARC ON A COMPRESSED GAS CYLINDER
8. DON'T ALLOW THE INSULATED PORTION OF THE ELECTRODE HOLDER TO TOUCH THE WELDING GROUND WHILE CURRENT IS FLOWING.
9. SHUT OFF POWER AND UNPLUG MACHINE WHEN REPAIRING OR ADJUSTING. Inspect before every use. Only use identical replacement part.
10. FOLLOW ALL MANUFACTURER'S RULES on operating switches and making adjustments.
11. ALWAYS WEAR PROTECTIVE CLOTHING when welding . This includes: long sleeved shirt( leather sleeves), protective apron without pockets, long protective pants and boots. When handling hot materials, wear asbestos gloves.
12. ALWAYS WEAR A WELDER'S HELMET WITH PROTECTIVE EYE PIECE when welding. Arcs may cause blindness. Wear a protective cap underneath the helmet.
13. WHEN WELDING OVERHEAD, BEWARE OF HOT METAL DROPPINGS. Always protect the head, hand, feet and body.
14. KEEP A FIRE EXTINGUISHER CLOSE BY AT ALL TIMES.
15. DO NOT EXCEED THE DUTY CYCLE OF THE MACHINE. The rated cycle of a welding machine is the percentage of a ten minute period that the machine can operate safely at a given output setting.
16. KEEP ALL CHILDREN AWAY FROM WORK AREA. When storing equipment, make sure it is out of reach of children.
17. GUARD AGAINST ELECTRIC SHOCK. DO not work when tired. Do not let body come In' contact with grounded surfaces.

## 1. BRIEF INTRODUCTION

PAC40M INVERTER AIR PLASMA CUTTING MACHINES are all our own high-new technical products with special purpose power parts and up-to-date inverter control IC. The machines hold a safe lead of traditional products and other inverter cutting machines by their cutting thickness ,seam smooth degree, arc generation and cutting current ,and the machine is compressed air and the cost of cutting is very low. All stainless steel,copper,Aluminum,titanium, cast steel,alloy steel,carbon steel and compound metal material can be cutting in all position.

## 2. OPERATING CONDITION AND WORK SURROUNDING

### 1. Operating condition: Reliable grounding protection

Voltage of power source: 1 x230V  $\pm$  10%

### 2. WORK SURROUNDING

Relative humidity: Not more than 90%(average monthly temperature not more than 20 °C)

Ambient temperature: -10°C~ 40°C

The cutting site should have no harmful gas ,chemicals,molds and inflammable matter, explosive and corrosive medium. Avoiding rain water. And operating in rain is not allowed.

## 3. MAIN TECHNICAL SPECIFICATIONS

MODEL	PAC40M
Power Voltage	1x230V $\pm$ 10%;50/60Hz
Input Current	28.5A
Rated Output Current	40A
Current .Adjusting Range	15-40A
No-load Voltage	200V
Rated Duty Cycle	60%
Working Mode	Contacting/notContacting
Air Pressure	0.2-0.4MPa
Max. Cutting Thickness	12mm
After Flow Time	10S
Outline Dimensions	390 $\times$ 190 $\times$ 290

## 4. DESCRIPTION OF THE ERECTION

1. The voltage of the output ends is very high. Don't touch with the output ends, cutting torch and other conductive parts while setting up an electric circuit.

2. For the safety of the equipment and the persons, the customer must correctly make grounding or protection according to the power supply system:using 4 mm<sup>2</sup> lead to connect the protection grounding of the cutting machine.

3. Cutting operating should be carried out in dry and good ventilating area. The surrounding objects should be not less than 0.5m away from the cutting machine.

4 . Before cutting , the operator should read the operation instructions carefully and use the machine correctly.

## 5. THE SKETCH OF FUNCTION AND CONNECT ING

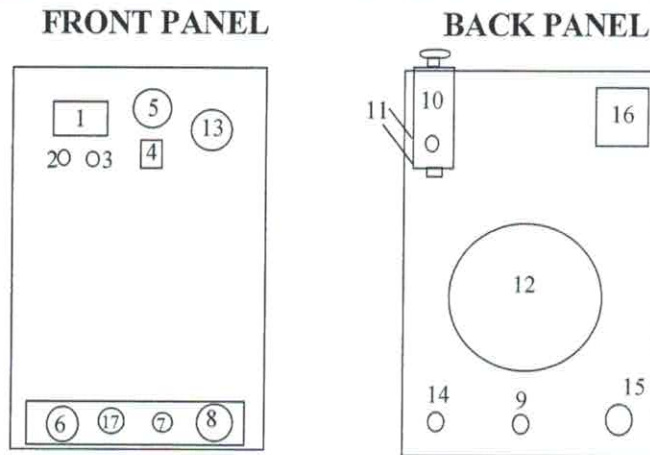

1. indication of cutting current 2.power indication 3. warning indication 4. cutting/testing gas switch  
 5. cutting current regulator 6. cutting torch cable 7. torch control 8. workpiece cable  
 9. Gas inlet 10. air pressure-reduced valve 11. pressure air entrance 12. fan  
 13. indication of air pressure-reduced valve 14. grounding column 15. input cable  
 16.power switch 17.pilotarc

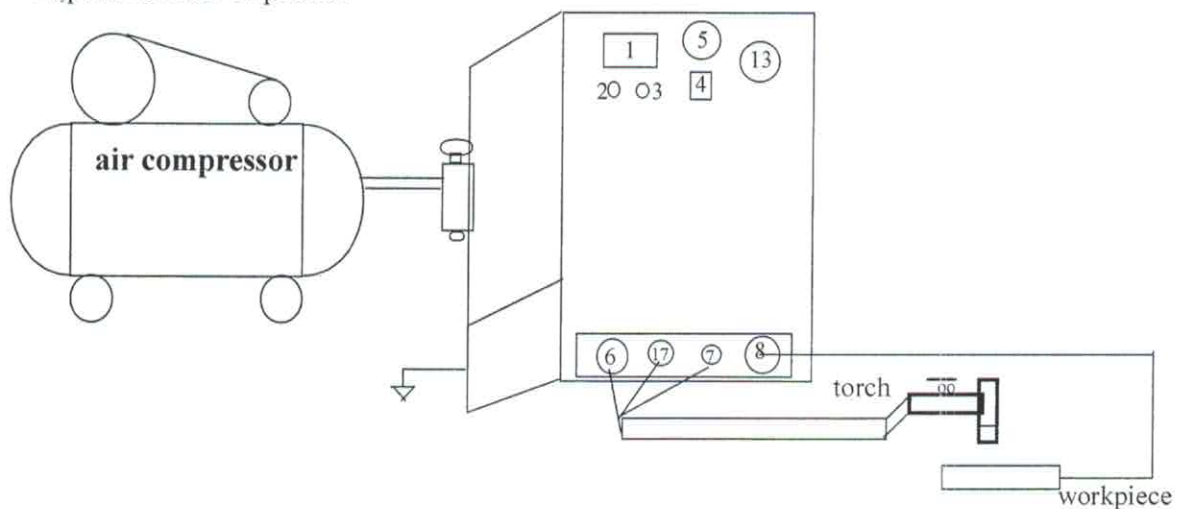

## **6. METHOD OF THE OPERATION**

1. Connect the machine correctly according the sketch. And switch on the air compressor until to its rated pressure. It will be turned off automatically to adjust the air pressure-reduced valve to the proper value.(0.2-0.35MPa generally)

2. Join the power switch of the cutting machine. The power indication lamp lights.The cooling fan begins working. Put the function switch in the position of "air testing" .Then the air spouts from the cutting torch. Let the function switch in the position of " cutting", and press the torch switch. The air spouts from the torch also.

3. Selecting suitable cutting current and air pressure according to the thickness and material of the workpiece and the cutting speed.The selecting standard for the spray nozzle of the torch: The spray nozzle not change color while cutting.

4. CUTTING: Hold the cutting torch in the beginning position, and let the nozzle towards the workpiece with 15 angle of inclination. The nozzle touches the workpiece, and press the torch switch, Now flow the air first and high frequency arc generated.The high frequency can be cut off automatically after the arc generation ,Begin to move the cutting torch after the workpiece is pierced through. Loosen the switch after finish cutting.

**7.This product is subject to the understanding that if any defect in manufacture or material shall appear within 12 months from date of consumer sale , the manufacturer will arrange for such defect to be rectified without charge on the sales invoice and warranty card. (except for any personal trouble)**

## General Troubles and Problem Solving

TROUBLE	CAUSES	PROBLEM SOLVING
Power lamp not light	<ol style="list-style-type: none"> <li>1. No electricity input</li> <li>2. Power switch of machine fails</li> </ol>	<ol style="list-style-type: none"> <li>1. Check incoming line</li> <li>2. Replace the switch</li> </ol>
Fan not rotating	<ol style="list-style-type: none"> <li>1. Fan power line is off</li> <li>2. enclosure blocks the fan due to deformation</li> <li>3. The fan fail</li> </ol>	<ol style="list-style-type: none"> <li>1. reconnect the line</li> <li>2. reform the enclosure</li> <li>3. replace the fan</li> </ol>
Warning lamp lights	<ol style="list-style-type: none"> <li>1. Over heat</li> <li>2. Over current</li> </ol>	<ol style="list-style-type: none"> <li>1. Cutting after cooling</li> <li>2. Input voltage too low or the machine fails</li> </ol>
No output	<ol style="list-style-type: none"> <li>1. over current protection</li> <li>2. The machine fails</li> </ol>	<ol style="list-style-type: none"> <li>1. Over load using</li> <li>2. Maintenance in manufacturer or service center</li> </ol>
Output current decreased	<ol style="list-style-type: none"> <li>1. Input voltage too low</li> <li>2. Input line is too thin</li> </ol>	<ol style="list-style-type: none"> <li>2. Power line is thickened</li> </ol>
Current can not be regulated	<ol style="list-style-type: none"> <li>1. connecting line of the potentiometer is off</li> <li>2. Potentiometer of current regulation fails</li> </ol>	<ol style="list-style-type: none"> <li>1. Reconnecting the line</li> <li>2. Replace the potentiometer</li> </ol>
High frequency arc can not be generated	<ol style="list-style-type: none"> <li>1. The switch fails</li> <li>2. Incorrect selection for the air flow, the electrode fails</li> <li>3. High frequency arc generator fails</li> </ol>	<ol style="list-style-type: none"> <li>1. Replace the switch</li> <li>2. Replace the electrode</li> <li>3. Replace the high frequency arc generator</li> </ol>

<b>WARNING</b>	<ul style="list-style-type: none"> <li>Do not touch electrically live parts or electrode with skin or wet clothing.</li> <li>Insulate yourself from work and ground.</li> </ul>	<ul style="list-style-type: none"> <li>Keep flammable materials away.</li> </ul>	<ul style="list-style-type: none"> <li>Wear eye, ear and body protection.</li> </ul>
Spanish <b>AVISO DE PRECAUCION</b>	<ul style="list-style-type: none"> <li>No toque las partes o los electrodos bajo carga con la piel o ropa mojada.</li> <li>Aíselese del trabajo y de la tierra.</li> </ul>	<ul style="list-style-type: none"> <li>Mantenga el material combustible fuera del área de trabajo.</li> </ul>	<ul style="list-style-type: none"> <li>Protéjase los ojos, los oídos y el cuerpo.</li> </ul>
French <b>ATTENTION</b>	<ul style="list-style-type: none"> <li>Ne laissez ni la peau ni des vêtements mouillés entrer en contact avec des pièces sous tension.</li> <li>Isolez-vous du travail et de la terre.</li> </ul>	<ul style="list-style-type: none"> <li>Gardez à l'écart de tout matériel inflammable.</li> </ul>	<ul style="list-style-type: none"> <li>Protégez vos yeux, vos oreilles et votre corps.</li> </ul>
German <b>WARNUNG</b>	<ul style="list-style-type: none"> <li>Berühren Sie keine stromführenden Teile oder Elektroden mit Ihrem Körper oder feuchter Kleidung!</li> <li>Isolieren Sie sich von den Elektroden und dem Erdboden!</li> </ul>	<ul style="list-style-type: none"> <li>Entfernen Sie brennbares Material!</li> </ul>	<ul style="list-style-type: none"> <li>Tragen Sie Augen-, Ohren- und Körperschutz!</li> </ul>
Portuguese <b>ATENÇÃO</b>	<ul style="list-style-type: none"> <li>Não toque partes elétricas e electrodos com a pele ou roupa molhada.</li> <li>Isole-se da peça e terra.</li> </ul>	<ul style="list-style-type: none"> <li>Mantenha inflamáveis bem guardados.</li> </ul>	<ul style="list-style-type: none"> <li>Use proteção para a vista, ouvido e corpo.</li> </ul>
Japanese <b>注意事項</b>	<ul style="list-style-type: none"> <li>通電中の電気部品、又は溶材にヒブやぬれた布で触れないこと。</li> <li>施工物やアースから身体が絶縁されている様にして下さい。</li> </ul>	<ul style="list-style-type: none"> <li>燃えやすいものの側での溶接作業は絶対にしてはなりません。</li> </ul>	<ul style="list-style-type: none"> <li>目、耳及び身体に保護具をして下さい。</li> </ul>
Chinese <b>警告</b>	<ul style="list-style-type: none"> <li>皮肤或湿衣物切勿接触带电部件及焊条。</li> <li>使你自已與地面和工件絕緣。</li> </ul>	<ul style="list-style-type: none"> <li>把一切易燃物品移離工作場所。</li> </ul>	<ul style="list-style-type: none"> <li>佩戴眼、耳及身體勞動保護用具。</li> </ul>
Korean <b>위험</b>	<ul style="list-style-type: none"> <li>전도체나 용접봉을 젖은 헝겊 또는 피부로 절대 접촉치 마십시오.</li> <li>모재와 접지를 접촉치 마십시오.</li> </ul>	<ul style="list-style-type: none"> <li>인화성 물질을 접근 시키지 마십시오.</li> </ul>	<ul style="list-style-type: none"> <li>눈, 귀와 몸에 보호장구를 착용하십시오.</li> </ul>
Arabic <b>تحذير</b>	<ul style="list-style-type: none"> <li>لا تلمس الأجزاء التي يسري فيها التيار الكهربائي أو الإلكترود بجلد الجسم أو الملابس المبللة بالماء.</li> <li>ضع عازلا على جسمك خلال العمل.</li> </ul>	<ul style="list-style-type: none"> <li>ضع المواد القابلة للاشتعال في مكان بعيد.</li> </ul>	<ul style="list-style-type: none"> <li>ضع أدوات وملابس واقية على عينيك وأذنيك وجسمك.</li> </ul>

READ AND UNDERSTAND THE MANUFACTURER'S INSTRUCTION FOR THIS EQUIPMENT AND THE CONSUMABLES TO BE USED AND FOLLOW YOUR EMPLOYER'S SAFETY PRACTICES.

SE RECOMIENDA LEER Y ENTENDER LAS INSTRUCCIONES DEL FABRICANTE PARA EL USO DE ESTE EQUIPO Y LOS CONSUMIBLES QUE VA A UTILIZAR, SIGA LAS MEDIDAS DE SEGURIDAD DE SU SUPERVISOR.

LISEZ ET COMPRENEZ LES INSTRUCTIONS DU FABRICANT EN CE QUI REGARDE CET EQUIPMENT ET LES PRODUITS A ETRE EMPLOYES ET SUIVEZ LES PROCEDURES DE SECURITE DE VOTRE EMPLOYEUR.

LESEN SIE UND BEFOLGEN SIE DIE BETRIEBSANLEITUNG DER ANLAGE UND DEN ELEKTRODENEINSATZ DES HERSTELLERS. DIE UNFALLVERHÜTUNGSVORSCHRIFTEN DES ARBEITGEBERS SIND EBENFALLS ZU BEACHTEN.

			
<ul style="list-style-type: none"> <li>● Keep your head out of fumes.</li> <li>● Use ventilation or exhaust to remove fumes from breathing zone.</li> </ul>	<ul style="list-style-type: none"> <li>● Turn power off before servicing.</li> </ul>	<ul style="list-style-type: none"> <li>● Do not operate with panel open or guards off.</li> </ul>	<b>WARNING</b>
<ul style="list-style-type: none"> <li>● Los humos fuera de la zona de respiración.</li> <li>● Mantenga la cabeza fuera de los humos. Utilice ventilación o aspiración para gases.</li> </ul>	<ul style="list-style-type: none"> <li>● Desconectar el cable de alimentación de poder de la máquina antes de iniciar cualquier servicio.</li> </ul>	<ul style="list-style-type: none"> <li>● No operar con panel abierto o guardas quitadas.</li> </ul>	Spanish <b>AVISO DE PRECAUCION</b>
<ul style="list-style-type: none"> <li>● Gardez la tête à l'écart des fumées.</li> <li>● Utilisez un ventilateur ou un aspirateur pour ôter les fumées des zones de travail.</li> </ul>	<ul style="list-style-type: none"> <li>● Débranchez le courant avant l'entretien.</li> </ul>	<ul style="list-style-type: none"> <li>● N'opérez pas avec les panneaux ouverts ou avec les dispositifs de protection enlevés.</li> </ul>	French <b>ATTENTION</b>
<ul style="list-style-type: none"> <li>● Vermeiden Sie das Einatmen von Schweißrauch!</li> <li>● Sorgen Sie für gute Be- und Entlüftung des Arbeitsplatzes!</li> </ul>	<ul style="list-style-type: none"> <li>● Strom vor Wartungsarbeiten abschalten! (Netzstrom völlig öffnen; Maschine anhalten!)</li> </ul>	<ul style="list-style-type: none"> <li>● Anlage nie ohne Schutzgehäuse oder Innenschutzverkleidung in Betrieb setzen!</li> </ul>	German <b>WARNUNG</b>
<ul style="list-style-type: none"> <li>● Mantenha seu rosto da fumaça.</li> <li>● Use ventilação e exaustão para remover fumo da zona respiratória.</li> </ul>	<ul style="list-style-type: none"> <li>● Não opere com as tampas removidas.</li> <li>● Desligue a corrente antes de fazer serviço.</li> <li>● Não toque as partes elétricas nuas.</li> </ul>	<ul style="list-style-type: none"> <li>● Mantenha-se afastado das partes moventes.</li> <li>● Não opere com os painéis abertos ou guardas removidas.</li> </ul>	Portuguese <b>ATENÇÃO</b>
<ul style="list-style-type: none"> <li>● ヒュームから頭を離すようにして下さい。</li> <li>● 換気や排煙に十分留意して下さい。</li> </ul>	<ul style="list-style-type: none"> <li>● メンテナンス・サービスに取りかかる際には、まず電源スイッチを必ず切して下さい。</li> </ul>	<ul style="list-style-type: none"> <li>● パネルやカバーを取り外したまま機械操作をしないで下さい。</li> </ul>	Japanese <b>注意事項</b>
<ul style="list-style-type: none"> <li>● 頭部遠離煙霧。</li> <li>● 在呼吸區使用通風或排風器除煙。</li> </ul>	<ul style="list-style-type: none"> <li>● 維修前切斷電源。</li> </ul>	<ul style="list-style-type: none"> <li>● 儀表板打開或沒有安全罩時不準作業。</li> </ul>	Chinese <b>警告</b>
<ul style="list-style-type: none"> <li>● 얼굴로부터 용접가스를 멀리하십시오.</li> <li>● 호흡지역으로부터 용접가스를 제거하기 위해 가스제거기나 통풍기를 사용하십시오.</li> </ul>	<ul style="list-style-type: none"> <li>● 보수전에 전원을 차단하십시오.</li> </ul>	<ul style="list-style-type: none"> <li>● 패널이 열린 상태로 작동치 마십시오.</li> </ul>	Korean <b>위험</b>
<ul style="list-style-type: none"> <li>● ابتعد رأسك بعيداً عن الدخان.</li> <li>● استعمل التهوية أو جهاز ضغط الدخان للخارج لكي تبعد الدخان عن المنطقة التي تتنفس فيها.</li> </ul>	<ul style="list-style-type: none"> <li>● اقطع التيار الكهربائي قبل القيام بأية صيانة.</li> </ul>	<ul style="list-style-type: none"> <li>● لا تشغيل هذا الجهاز إذا كانت الأغطية الحديدية الواقية ليست عليه.</li> </ul>	Arabic <b>تحذير</b>

**LEIA E COMPREENDA AS INSTRUÇÕES DO FABRICANTE PARA ESTE EQUIPAMENTO E AS PARTES DE USO, E SIGA AS PRÁTICAS DE SEGURANÇA DO EMPREGADOR.**

使う機械や溶材のメーカーの指示書をよく読み、まず理解して下さい。そして貴社の安全規定に従って下さい。

請詳細閱讀並理解製造廠提供的說明以及應該使用的銀焊材料，並請遵守貴方的有關勞動保護規定。

이 제품에 동봉된 작업지침서를 숙지하시고 귀사의 작업자 안전수칙을 준수하시기 바랍니다.

اقرأ بتمعن وافهم تعليمات المصنع المنتج لهذه المعدات والمواد قبل استعمالها واتبع تعليمات الوقاية لصاحب العمل.



8.ACCESSORIES:SEE PACKING LIST,PLEASE

PACKING LIST

★★

<i>model</i>	<i>quantity</i>	<i>remark</i>	<i>note</i>
PAC40M cutting machine	1		PACKING 1)
Cutting torch	1		PACKING 1)
Output cable	1		PACKING 1)
Operation instructions	1		PACKING 1)
Certificate of quality	1		PACKING 1)

No.

-----

Certificate of quality

Name of product:DC INVERTER AIR PLASMA CUTTING MACHINE

Type of product: PAC40M

Packing No: 252104728

Test results of this welder fulfils

technical requirements and its release

from the works is granted.

Inspector

INSP.1

Date

12 29 2021



